

Hülsen

Collar Coupelle Manicotti Manguitos

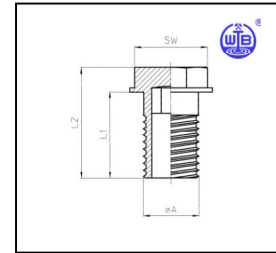
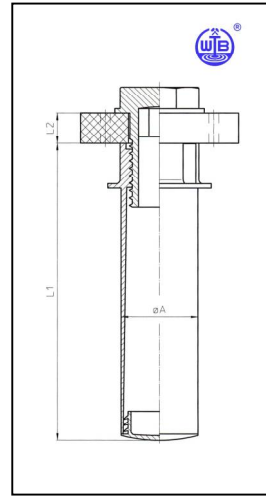
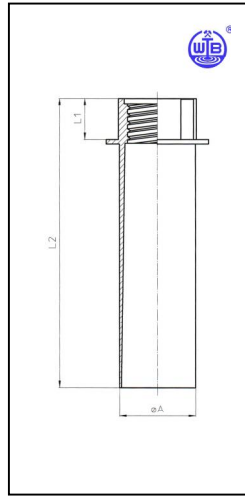
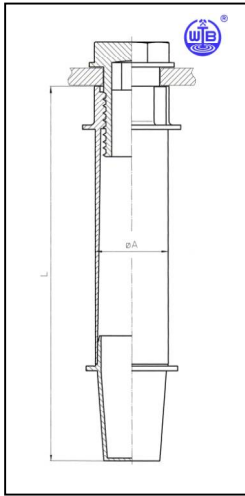

Gewinde	Thread	Filetage	H (mm)	Andere Höhen auf Anfrage Other heights on request Autres hauteurs sur demand
1" Ww D = 31 mm / 39 mm			50	
			70	
			90	
			100	
1 1/4" Ww D = 39 mm			110	
			120	
			150	
			200	

Material / material / matériau /
materiale / material:

PPN

Muttern

Nuts Ecrous Dadi Tuercas

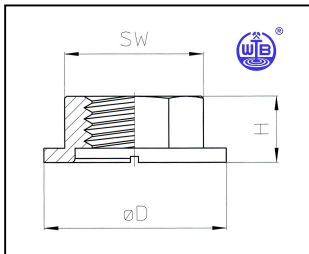

Gewinde	Thread	Filetage	H (mm)	D (mm)	SW (mm)
M 20 / M 22 / 7/8" Ww			17	45	30
M 24 / M 27 / 1" Ww / R 3/4"			17	45	36
M 30 / R 1" / 1 1/4" Ww / 1 3/8" WW			17	50	42
R 1 1/2"			7	75	17
R 2"			9	88	17

Material / material / matériau / materiale / material:

PPN

PPH

PVDF

Gewinderinge

Grommets Bagues taraudés

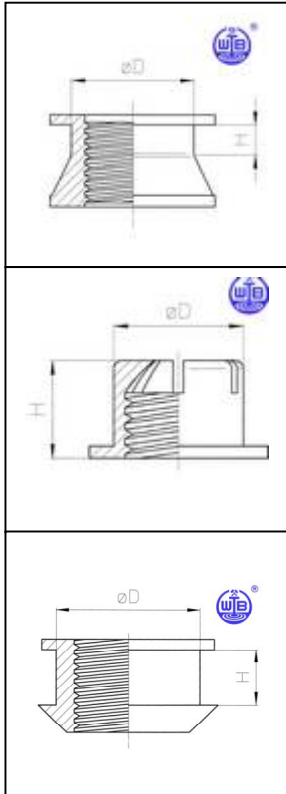

Gewinde	Thread	Filetage	D (mm)	H (mm)	
1 1/4" Ww	1 3/8" Ww		40	15	22
				25	
1 1/4" Ww			39	4,5	4 - 6
				6,5	8 - 12
				15	16
				17	18
1" Ww	R 3/4"		32 34 36	8 - 15	13 - 17
				16 - 22	20
7/8" Ww			28	12	12 - 16
				17 - 22	

Andere Größen auf Anfrage
Autres sur demande
Others on demand

Material: PVC, 50 Shore

Minderungsventil

Reducing valve Soupape de reduction Valvola di minoratione

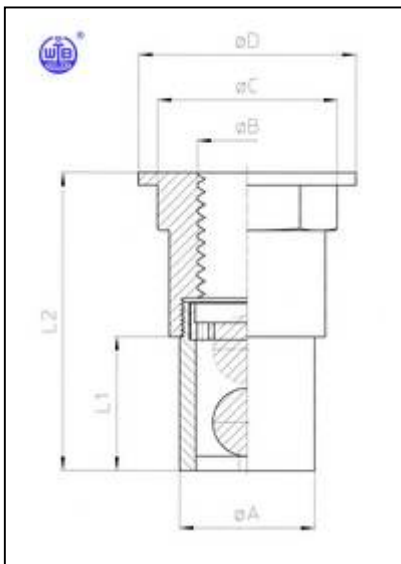

Gewinde Thread Filetage Fileto Rosca			
1" Ww	M 24	M 27	M 30
	1 1/4" Ww	R 3/4"	

Material / material / matériau / materiale / material:

PPN **PPH**

Spreizmuffen

**Expanding rings Bagues expansibles Taselli ad espansione
Tuerca de expansion**

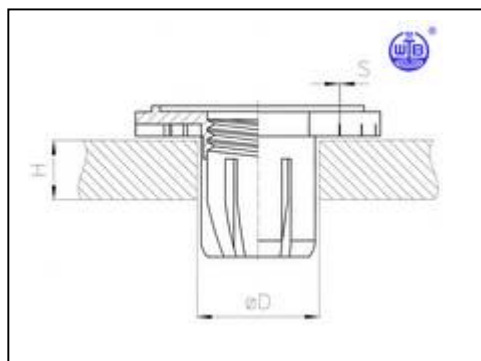
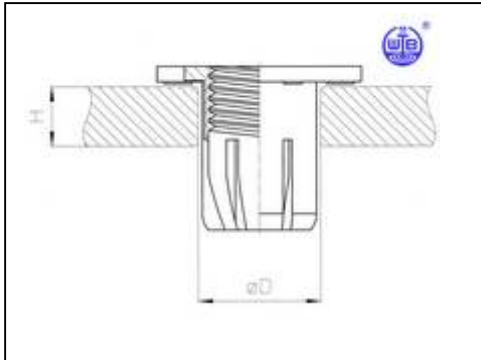

Material / material / matériau /
materiale / material:



Gewinde	D (mm) +0,5 / -0,2	H (mm)
1" WW	28	8 - 11
		12 - 17
		18 - 23
		24 - 29
	30	12 - 17
		18 - 23
		24 - 29
	32	12 - 17
		18 - 23
24 - 29		
M 20 x 2.5	24	12 - 17
M 24	27	12 - 17
R 3/4"	28	6
M 30	35	12 - 17
		6
		12 - 17
1 3/8"	38	12 - 17
		18 - 23
		6

Schraubdübel

Dowel

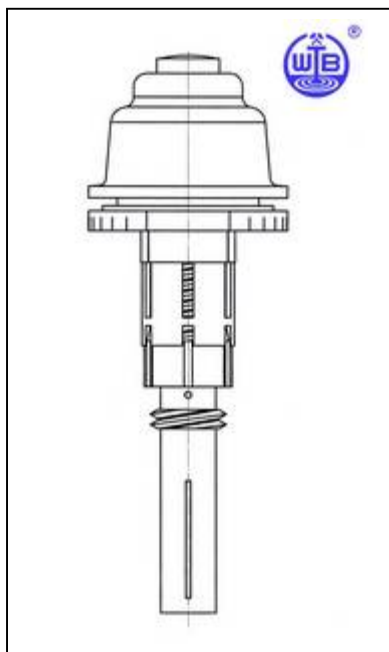

	Loch-Ø Hole-Ø	Bodenstärke Floor thickness
Min.	28	8
Max.	30	30

Material / material /
matériau / materiale:



Sattelstück

Adapter

adattatori

adaptadores

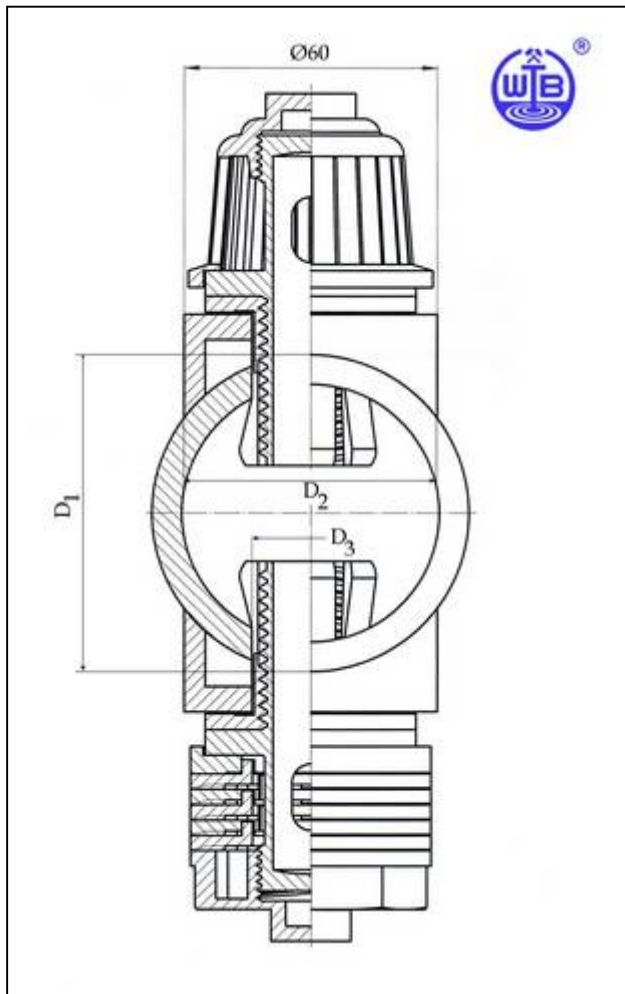

D1 (mm)	D2 (mm)	D3 (mm)
50	43	28
57	60	28
60		
63		
66		
68		
70		
73		
75		
76		
82		
83		
86		
90		
95		
100		
103		
110		
114		
122		
141		
154		
160		
175		
225		

Material / material / matériau /
materiale / material:

PPN

PPH

PVDF

Entleerungsring

Drain ring

Bague de purge

Außen-Ø (mm) Outside-Ø (mm)	Innen-Ø (mm) Inside-Ø (mm)	Höhe (mm) Height (mm)
57	34	6,5
73	51	8
Schlitzbreite 0,2mm oder 0,8 mm Slots 0,2 mm or 0,8 mm		

Material / material / matériau /
materiale / material:

PPH

PVDF

Zubehör Edelstahl

Accessories stainless steel

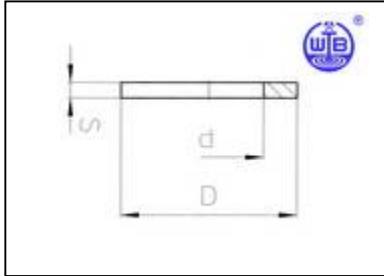

Unterlegscheibe
Washer Disque Piastrina Arandella

Material / material / matériau / materiale / material:

1.4401

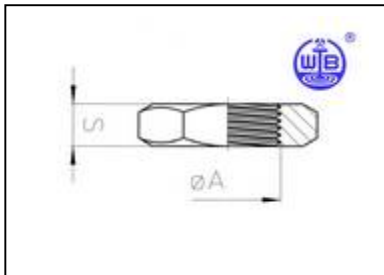

Mutter
Nut Ecrous Dadi Tuerca

Material / material / matériau / materiale / material:

1.4401

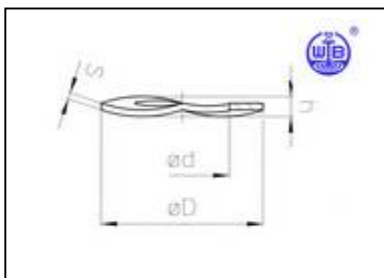

Federring
Spring washer Bague de serrage
rondella elastica

Material / material / matériau / materiale / material:

1.4310

Zubehör Edelstahl

Accessories stainless steel

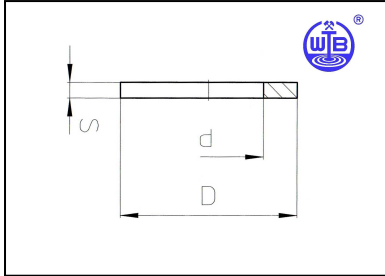

Unterlegscheibe
Washer Disque Piastrina Arandella

Material / material / matériau / materiale / material:

1.4571

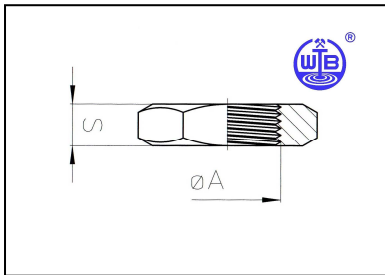

Mutter
Nut Ecrrous Dadi Tuerca

Material / material / matériau / materiale / material:

1.4571

1.4539

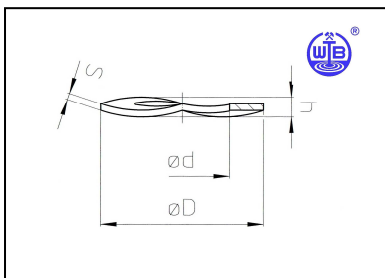

Federring
Spring washer Bague de serrage
rondella elastica

Material / material / matériau / materiale / material:

1.4301

Die von Ihnen gewünschte Düse ist nicht aufgeführt ?
Sie brauchen weitere Informationen über unsere Düsen ?
Sie benötigen weiteres Zubehör wie Kalibrierhülsen, Drehmomentschlüssel oder Distanzringe ?

Bitte zögern Sie nicht uns zu kontaktieren, dieser Katalog zeigt nur einen Ausschnitt unseres Programms. Fertigung von Düsen nach Ihren Zeichnungen nach Absprache.

The nozzle you're looking for isn't listed ?
You need further informations about our nozzles ?
You need further accessories like torque wrench or distance rings ?

Please don't hesitate to contact us, this catalogue just shows parts out of our programm.
Production of customised nozzles after collusion.

PPN	Für Temperaturen bis 40°C / for temperatures up to 40°C
PPH	Für Temperaturen bis 75°C / for temperatures up to 75°C
PVDF	Für Temperaturen bis 135°C / for temperatures up to 135°C

Glasfaser-verstärktes PP auf Anfrage / Glass fibres combined PP on demand

Anzugsdrehmoment bei der Montage:	max. 0,4 kpm / 4 Nm
Tightening torque when fitting:	max. 0,4 kpm / 4 Nm
Couple de serrage lors du montage:	max. 0,4 kpm / 4 Nm
Momento de torion durante el montaje :	max. 0,4 kpm / 4 Nm